

# Manual for the wind turbine Black 1500



**Volt-Watt-Ampere**



Carl-Sonnenscheinstrasse 17  
D-49429 Visbek

[www.vwa-deutschland.de](http://www.vwa-deutschland.de)  
0049 (0)4445-989433

# Contents

1. General advices

2. Security advices

3. Technical specifications

4. Assembly

5. Connection

6. Troubleshooting

7. Checkup and maintenance

## 1.General advices

Thank you very much for purchasing the wind turbine Black 1500. You have bought a premium product which silhouettes explicitly against products of our competitors. The wind turbines of the Black series have no magnetic detent torque and holding torque, which allows a start-up from wind speeds of 0.8 m/sec. From 1.8 m/sec on, you are able to be in loading area. The wires inside the mast will not roll up, because yaw control is made via abrasive ring contacts.

In order to get a bigger turbine's lifespan, there are some necessary advices for mounting the wind turbine assuredly and reliably.

Please notice that this manual is a part of the product and has to be followed strictly, so please read this manual carefully before installing the wind turbine. This manual should be positioned near the product and it should be given to possible new owners.

This manual describes the function, installation, operating and attendance of the wind turbine.

It addresses itself to the raiser of the turbine who should be technically experienced. If this is not the case, please let the installation be made by a technician.

The wind turbines BLACK are available in 12 or 24 Volt for charging batteries and in 48 Volt for supplying feed-in converters.

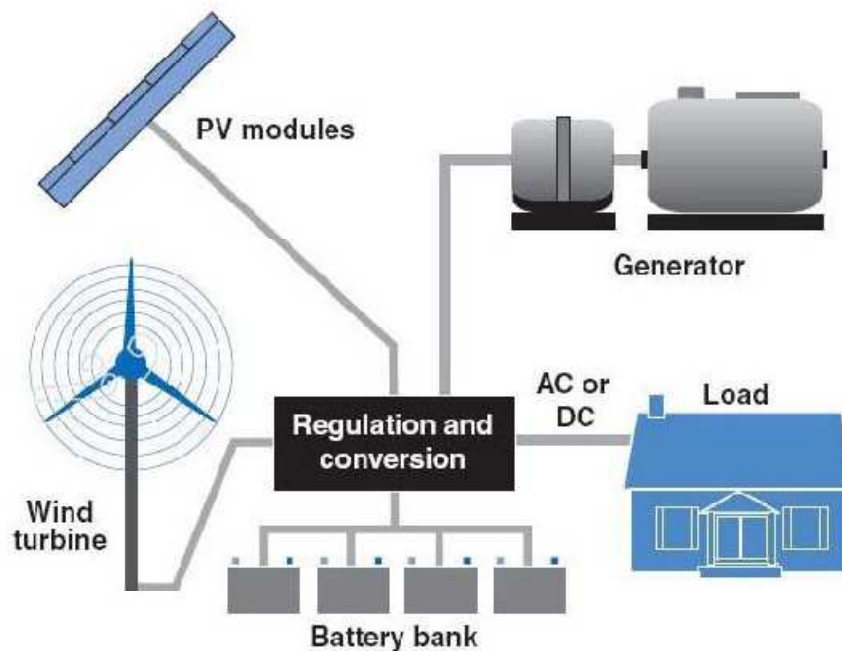

Wind turbines for battery charging which are connected to a solar panel, are appropriate to the following appliances: street lamps, supply of gauging stations, traffic management systems, emergency call systems, isolated systems like summer residences, garden plot, camping, advertisement, lighting of billboards, for primary health care in developing countries, Wireless Lan Access Point and everywhere, where there is no electrical connection. There is also available a feed-in converter for the wind turbine BLACK which are able to feed in the electricity network. These information are dependable, but the manufacturer does not take responsibility for impreciseness or omissions. The user of this information and of this product takes the full risk and responsibility. All specifications are changeable without any other messages. Wind turbines have to correspond to the local and national appointments, norms and laws, like other electric devices and sources, too. In some regions, you also need a building license before installation of the wind turbine. Before you start to mount the turbine, please check if you are allowed to install a turbine at your location.

## 2.Security advices

Wind turbines are dangerous devices because of the high rotational frequency and the created voltage, so please read these security advices carefully:

### **Mechanical risks:**

The rotating rotor is a big danger because it turns invisible, when a certain wind speed is reached. The angles of the rotor blades are very sharp-edged because of their aero dynamical body. Therefore you can hurt yourself even at slowly-rotating rotors. Never touch the rotating rotor, never try to stop it with your hands, mount the turbine only at locations where nobody has the possibility to touch it easily- that is very important!

The rotor blades are manufactured from plastics which even bears up against high wind speeds, nevertheless, you should keep distance to the rotating blades. Severe injuries can occur if a rotor blade breaks off. Especially this is the case when a blade was hit by a flying object. When a blade is damaged, you should stop the turbine immediately. When a rotor blade is damaged, the whole tower can be in danger because the generator can get a big unbalance. So please pay attention to the choice of your installation location. Only mount the wind generator to the tower when the connections of the charge controller or the feed-in converter are disconnected and bypassed (short-circuit of the generator may only be done when the rotor turns faster than 100 times per minute) or a rotor blade is tied to the tower, so that you cannot get hurt by the rotating rotor. The tower and the mounting to the tower have to resist the forces that are created by the wind force and by the strain. For this matter, a professional technician should be entrusted with the installation.

Please notice that you have to mount the tower with the help of at least two persons and that you have to follow the instructions and rules of the accident Ruihua and insurance association. When you mount the tower, please notice that no other persons may stand next to the tower. Encumbrances have to be secured with linkages during the process of lifting.

### **Electrical risks:**

A coasting wind turbine, especially the 48 V version, is able to create a DC voltage of more than 200 V. Please connect these devices only when you are technically experienced. These voltages can be fatal if you do not act accordant the instructions. Never touch uninsulated wire ends. Notice that uninsulated wires can do harm.

The wire, connective elements, plugs and other electrical components have to be dimensioned adequately at width, therewith wires do not warm up and cause a fire. The maximum current inside the wire can be up to 125 Ampere at a turbine 1500 Watt 12V.

Wires have to be laid securely in order to protect wires from mechanical damages. An open wire is very dangerous!

For fuse protection, you have to install a fuse to the feed cable, please do that as near as possible to the battery. A short-circuit of the battery cables and/or power lines has to be avoided on any account.

It has to be assured that the electric installation is only made by persons who have got expert knowledge.

The wind turbines are produced with a big accurateness, however it can happen that a wind turbine was not assembled completely or that a screw disengaged itself during transportation. Please check all single assemblies concerning damages and unfixed assemblies, e.g. like screws. The wind turbine has to be switched to the brake mode before a storm rises.

### 3. Technical specifications

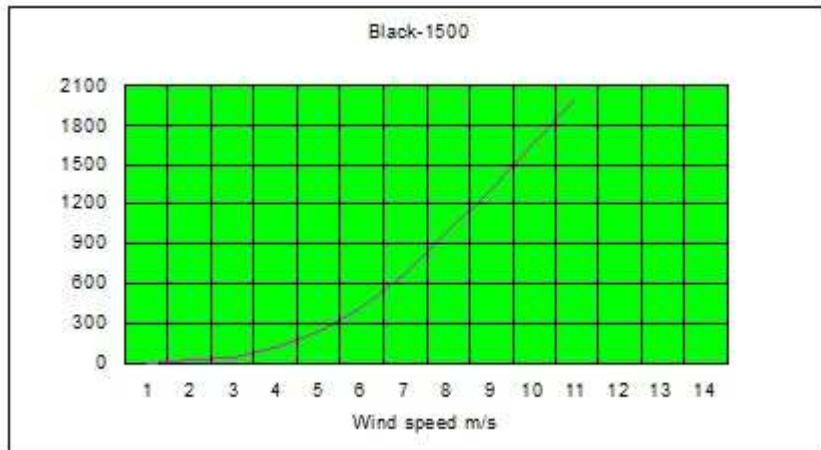

<b>Anlagentyp/Windturbine type</b>	<b>Black 1500</b>
<b>Vertrieb/ Distribution</b>	<b>VWA-FahrWind <a href="http://www.vwa-deutschland.de">www.vwa-deutschland.de</a></b>
<b>Rotor</b>	3 –Blatt/3-blades
<b>Nabenhöhe /Hub height</b>	12-20 m
<b>Nennleistung/Rated power</b>	1,5 kw
<b>Turm/Turmgewicht/Tower</b>	Variabel, Keine Dachmontage möglich
<b>Einschaltwind/Cut in wind speed</b>	0,8 m/s
<b>Nenngeschwindigkeit/Rated wind speed</b>	10,5 m/s
<b>Durchmesser/Rotor diameter</b>	3 m
<b>Rotormaterial/Blade material</b>	Nylon-Carbon
<b>Rotorfläche/Swept area</b>	7,06 m <sup>2</sup>
<b>Rotordrehzahl/Rotor speed RPM</b>	180-400 U/min
<b>Blattspitzengeschw./Blade tip speed</b>	63 m/s
<b>Drehzahlregelung/Leistungsbegrenzung Rotor speed control/Overspeed control</b>	Spannungs- und Stromüberwachung Voltage- and grid-control
<b>Hauptbremse/Main break system</b>	Elektronik
<b>2. Bremse/2nd brake system</b>	Manuell und Eklipse
<b>Nennleistung/Rated power</b>	1500 Watt
<b>Generatorspannung/Generator voltage</b>	72V-132V

## 4.Assembly

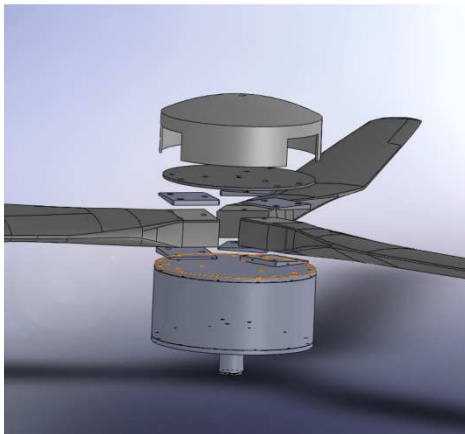
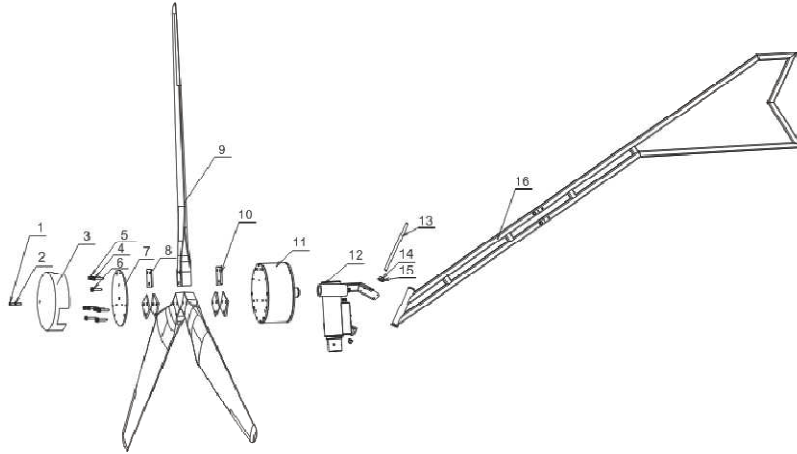

### position description number

- 1 M 8 x 70 screw 1
- 2 M8 spring washer 5
- 3 Cover 1
- 4 M10x80screw 9
- 5 M10 spring washer 9
- 6 M10 washer 9
- 7 Aluminum plate 1
- 8 Adapter for blade (up) 3
- 9 Blades made from carbon nylon 3
- 10 Adapter for blade (down) 3
- 11 Generator 1
- 12 Generator holder 1
- 13 M12 screw 2
- 14 M12 screw nut 1
- 15 M12 washer 1
- 16 Tail 1

The rotor blades are aerodynamically optimized, sounds are hardly recognizable. On lower rotary speeds up to 400 rotations per minute, almost no sounds can be recognized.

The combination of a holding-torque-free and a detent-torque-free generator and a balanced rotor blade allows to having a start-up from 0.8 m/s and a charging process from 1.8 m/sec.

The wind generator produces a three-phase alternating current, it makes sense to convert to continuous current with the charge controller, but not until it is short of the battery. The reason for it is that the consumption is lower at alternating current. You have to lay 3 wires from the wind generator to the charge controller, as seen on the following drawing.

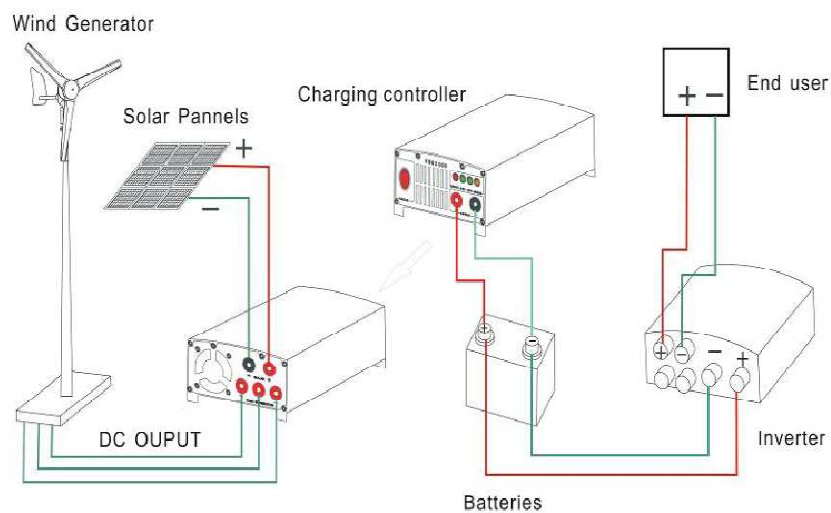

## 6.Troubleshooting

The wind turbine does not start to turn fast when:

- Brake of the charge controller is switched to I
- A short-circuit between the cores was created during connecting the cables
- An additionally installed stop switcher is switched on
- Rotor blades are mounted up-side-down
- Generator rubs against the syphon
- The position for the wind adjustment is too sluggish
- The rotor blades are not well balanced
- No battery is connected to the charge controller
- The locking device to the battery is defect
- There is not enough wind
- The wind turbine or the charge controller is defect

In order to find the mistake, we will have to do a process of elimination. Therefore you should disconnect the three cores of the wind turbine from the charge controller. When the wind turbine starts up, there has to be a mistake between the charge controller and the battery. When the turbine still turns very slowly, the mistake has to be between the charge controller and the wind turbine.

If the wind turbine does not have enough power:

- Wind speed is too low
- Installation location is not chosen well or the tower is not tall enough
- The cable diameter does not fit to the installed cable length
- The battery is too small, so that the charging end voltage is reached too early (the battery should at least have 100 Ah)
- The rotor is not balanced well

The wind turbine vibrates atop the tower:

- The rotor was not balanced well
- The wind turbine is in no vertical position
- The tower capacity has too much play
- The tower is not adequately robust

Before you contact the manufacturer concerning certain mistakes, please measure the following parameters and report them to the manufacturer:

1. How high is the wind speed
2. How high is the tower
3. Details on the installation location and its surrounding
4. Disconnect the three cores of the wind turbine from the charge controller and measure the AC voltage between each phase, from phase 1 to 2, from 2 to 3 and from 3 to phase 1. During constant wind conditions they should be nearly the same.
5. Measure the battery voltage
6. Which devices are connected to the battery

Are there any solar panels connected to the charge controller and which power (in Wp) and off-load voltage do these solar panels have.

## **7. Checkup and maintenance**

You should check up your wind turbine regularly in order to have fun with your turbine for a longer period.

The first checkup should be made on the first day after installation, then after one week and then after three months. After that, you can checkup your turbine in longer intervals.

Near coasts, you should do it every 6th month because of the higher salt content in the air, inside the country you should make a checkup once a year or after heavy storms. The best time to make a checkup is after winter time.

The following points should be made during checkup:

- Look for the vibrations atop the tower
- Check if the tower still is positioned vertically and if all wiring is tight
- Does the wind turbine turn easily into the wind
- Are the rotor blades still balanced well?
- When there is a damage at the blades, the wind turbine has to be stopped immediately. Take care if there are any small clefts or if anything is breaking off the edge of the blade.
- Are all screws still fastened to the generator?

Look carefully towards the cables, that there is no chafe mark recognizable.